

nEXO: The next generation ^{136}Xe
neutrinoless double beta decay
search

Igor Ostrovskiy
for the nEXO collaboration

Introduction

- “*The observation of neutrinoless double beta decay would indeed generate a fundamental shift in our understanding of elementary particles*” –NSAC committee report, 2014
- In spite of the massive effort by many collaborations, it has not been observed so far
- There is a strong recognized motivation for the next generation experiment, with the natural *aim* to cover the inverted hierarchy

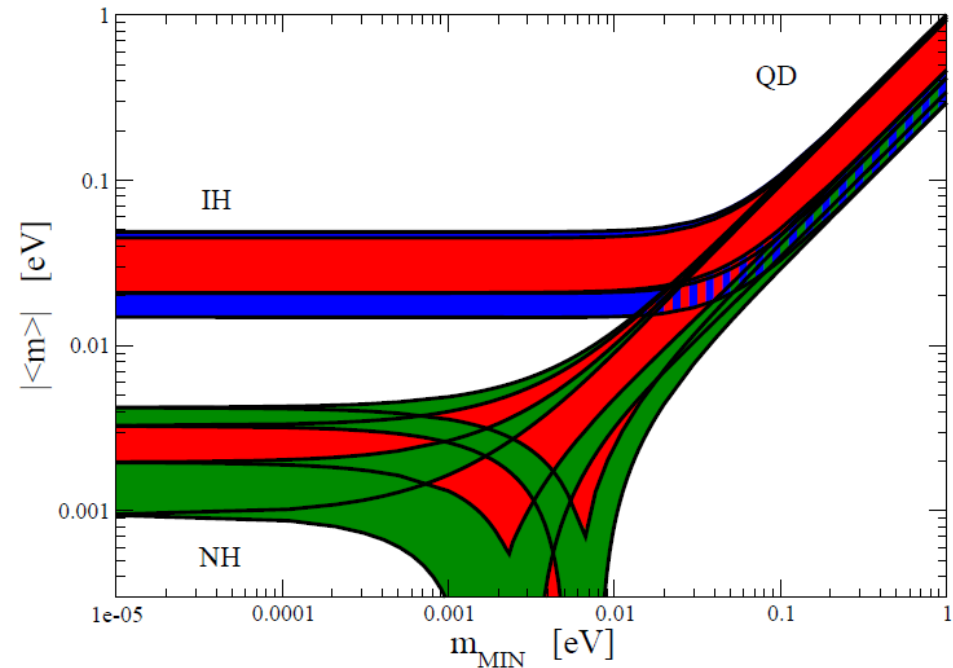

The red, blue and green bands correspond to different allowed regions for the unknown CP violating phases in the expression for $\langle m_{\beta\beta} \rangle$ and allowed 1σ variation in the other known neutrino parameters.

Phys. Rev. D **86**, 010001 (2012)

The stages of Enriched Xenon Observatory (EXO)

- Working since 1999 on a staged approach to $0\nu\beta\beta$ decay
- “Stage 1”: EXO-200
 - Took data from 05/2011 to 02/2014 producing some of the most competitive results in the field
 - EXO-200 reached and exceeded design specs (e.g., 1.4% energy resolution achieved vs. 1.6% expected)
 - After the WIPP incidents of 02/2014, it has been approved by DoE in 06/2015 to **restart and collect 3 more years of data**
 - Current plan is to restart by the end of the year
- EXO-200 is a very successful prototype for a larger, “Stage 2” detector, and it will still continue to produce physics results **unrelated to nEXO!**

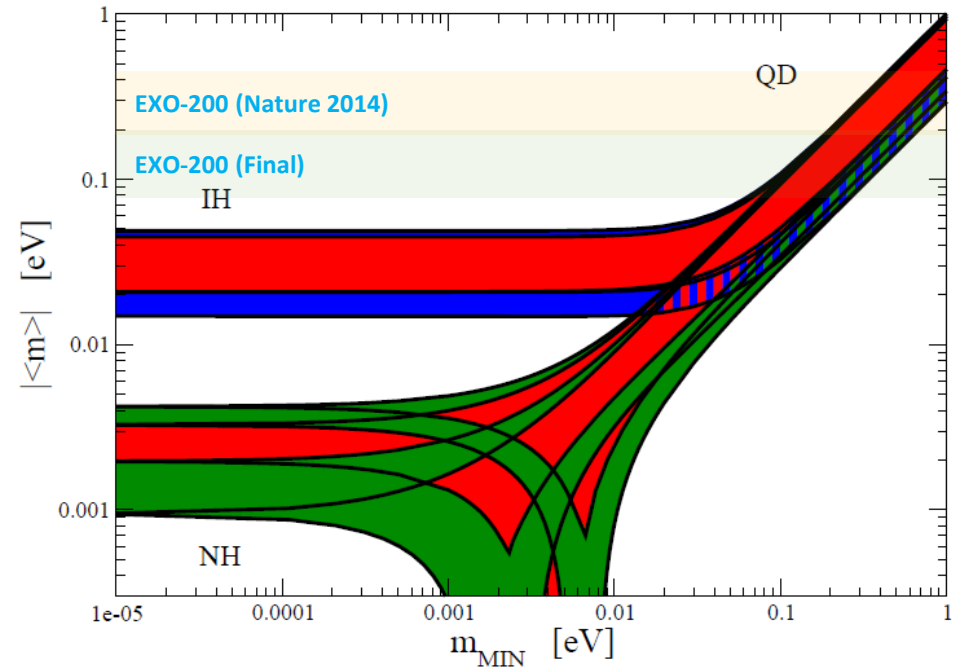

The stages of EXO (Enriched Xenon Observatory)

- “Stage 2”, nEXO, is being designed as a **5 tonne $L^{enr}Xe$** detector following closely the EXO-200 experience, with important differences
- nEXO is also a very flexible and cost effective detector with a clear upgrade path and the built-in capability to address possible future science scenarios making the best use of the enriched isotope
- nEXO is being designed for at least initial operation without Ba tagging. Barring any unexpected theoretical revelations, it should **cover the Inverted Hierarchy** region

Sensitivity as a function of time for the worst-case NME (Shell Model)

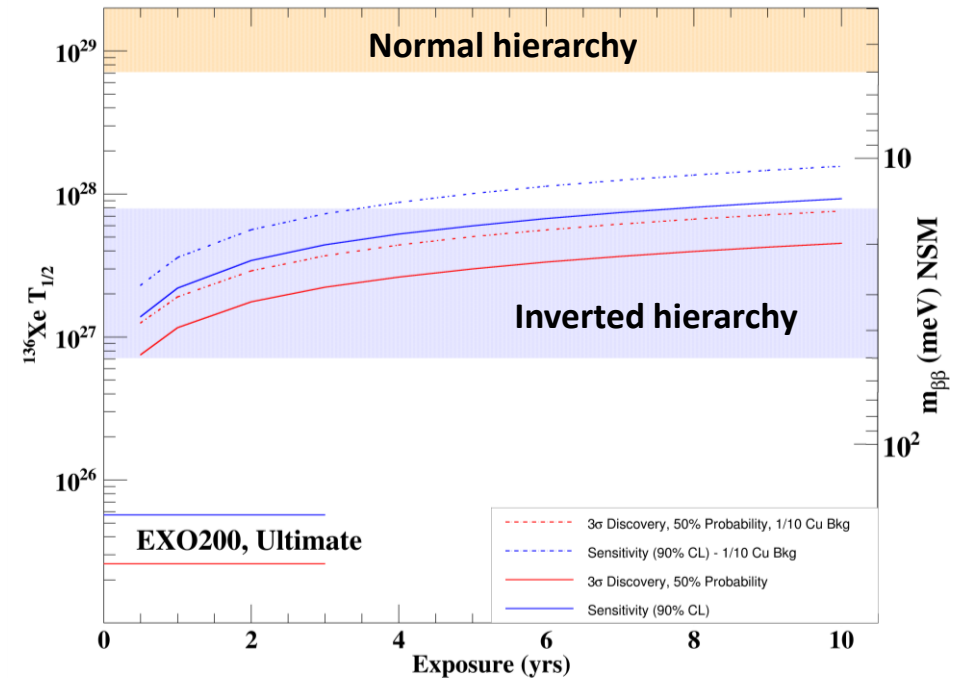

NSM: *Nucl.Phys. A* **818** (2009) 139

The stages of EXO (Enriched Xenon Observatory)

- “Stage 2”, nEXO, is being designed as a **5 tonne $L^{\text{enr}}\text{Xe}$** detector following closely the EXO-200 experience, with important differences
- nEXO is also a very flexible and cost effective detector with a clear upgrade path and the built-in capability to address possible future science scenarios making the best use of the enriched isotope
- nEXO is being designed for at least initial operation without Ba tagging. Barring any unexpected theoretical revelations, it should **cover the Inverted Hierarchy** region

Sensitivity as a function of time for the best-case NME (GCM)

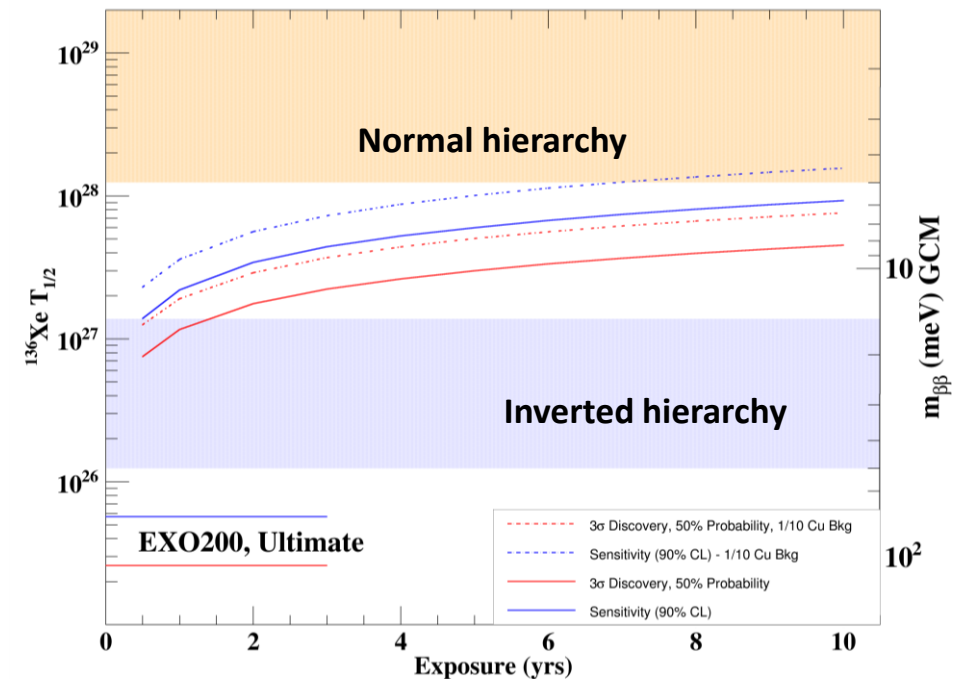

GCM: *Phys. Rev. Lett.* **105** (2010) 252503

From EXO-200 to nEXO

- EXO-200 demonstrated principle of a homogenous TPC capable of controlling backgrounds by a **combination** of **energy resolution**, **event topology**, and **event location**
- nEXO will take better advantage of all three (pending certain R&D):
 - Bigger detector w/o central cathode – better discrimination of external bkg with position dependent fit
 - Better photodetection and new charge collection scheme with cold electronics – better energy resolution and multiplicity metrics

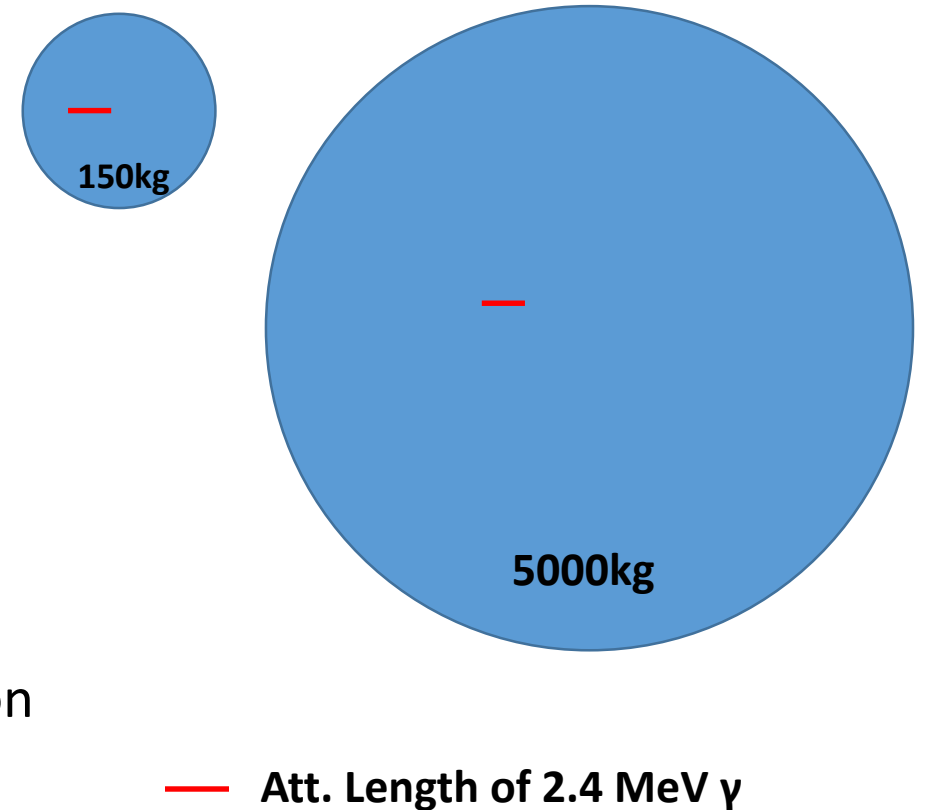

From EXO-200 to nEXO: bigger, with cleaner core volume

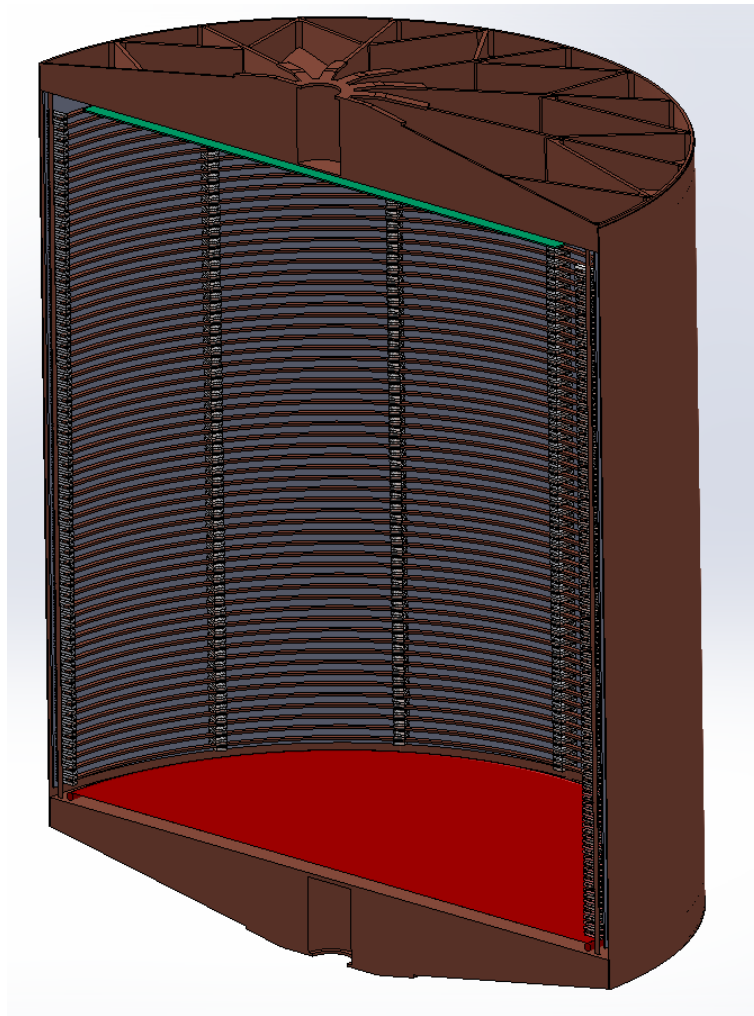

130
cm

- Based on EXO-200 experience, we plan to do standoff distance fit in **(almost) whole volume**
- No central cathode means **no source of Bi-214 gammas in the core volume**

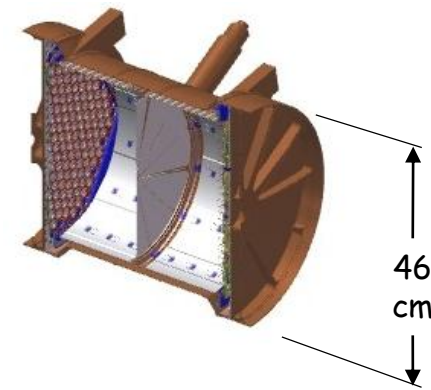

46
cm

The role of standoff in background control of a big detector

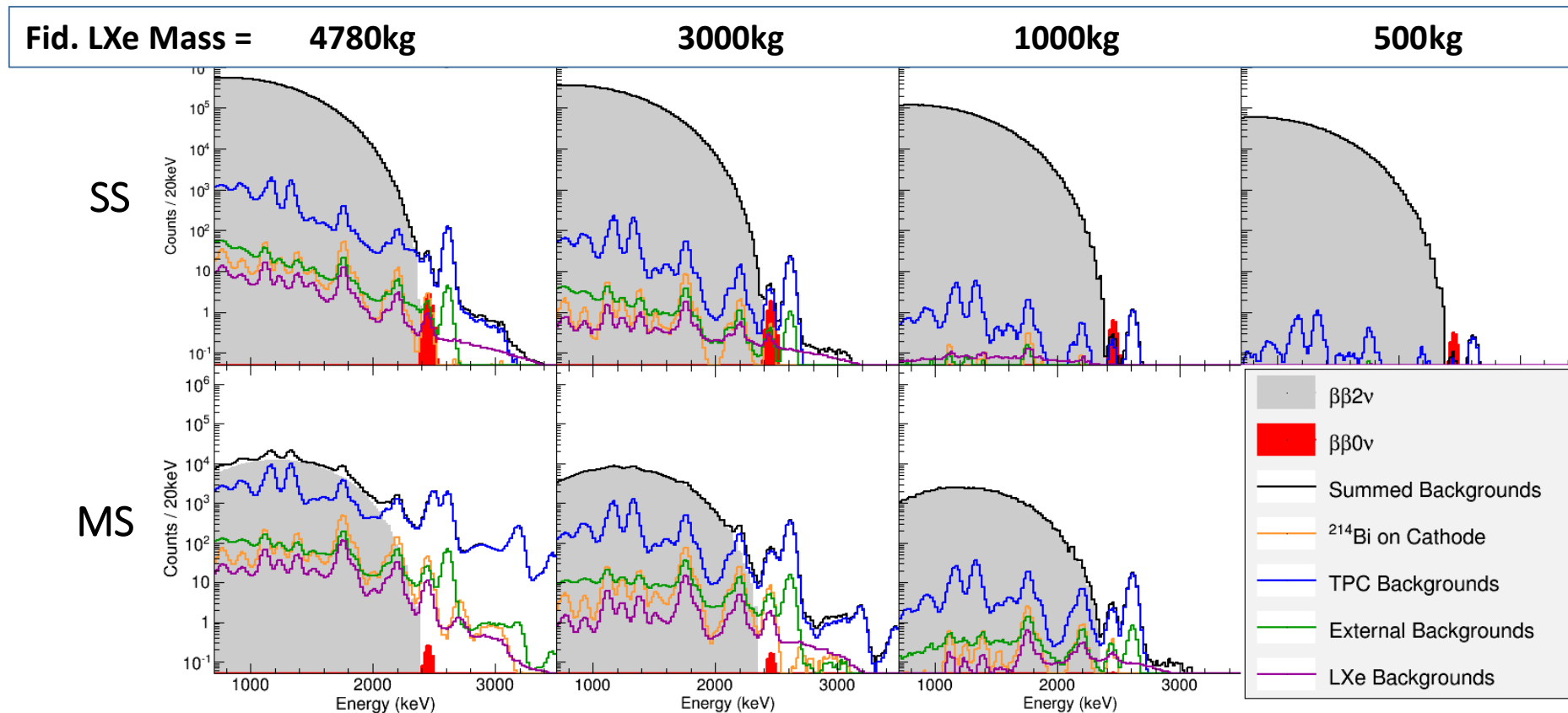

- Example assumes:
- 5 yrs of data
 - Projected backgrounds
 - $T_{1/2}^{0\nu} = 6.6 \times 10^{27}$ yr

Full volume **likelihood fit** will always **outperform simple fid. cut**, as long as one can model the shape of probability density functions adequately

From EXO-200 to nEXO: new charge collection

- 10 cm x 10 cm tile
- Metallized strips on fused silica
- 60 orthogonal channels (30x30)
- 3 mm strip pitch (vs. 9 mm wire pitch in EXO-200)
- Strip intersections isolated with silica
- Currently being tested at LXe setup
 - 9kg LXe cell, 1.7cm drift, 1 kV/cm
 - Tile prototypes by nEXO

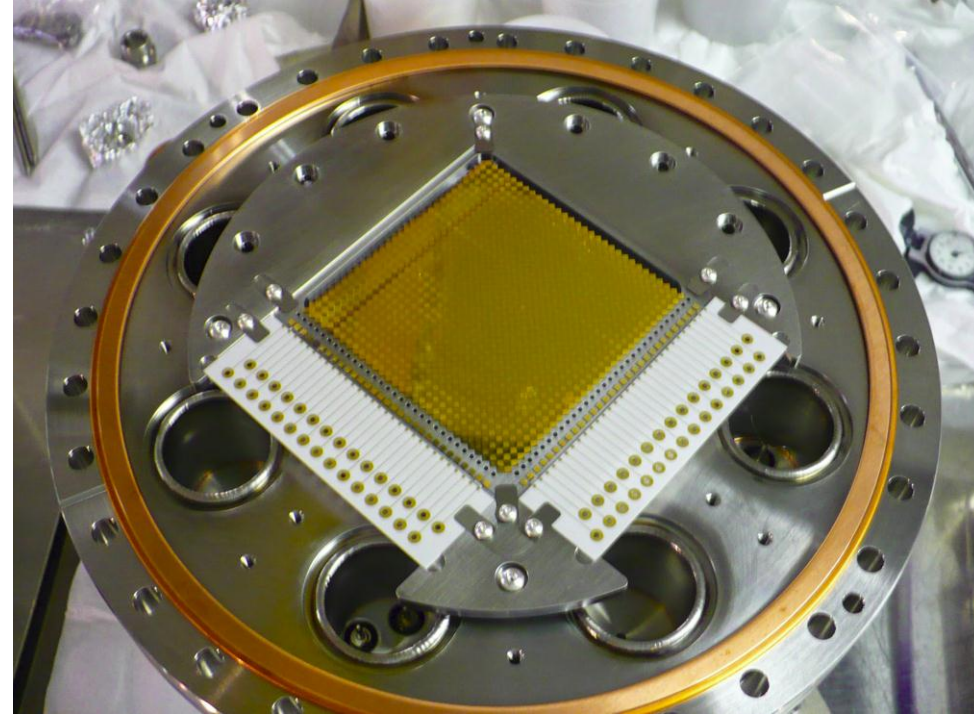

First data / (crude) MC comparison!

7-hour ionization-only spectrum from single strip located over source

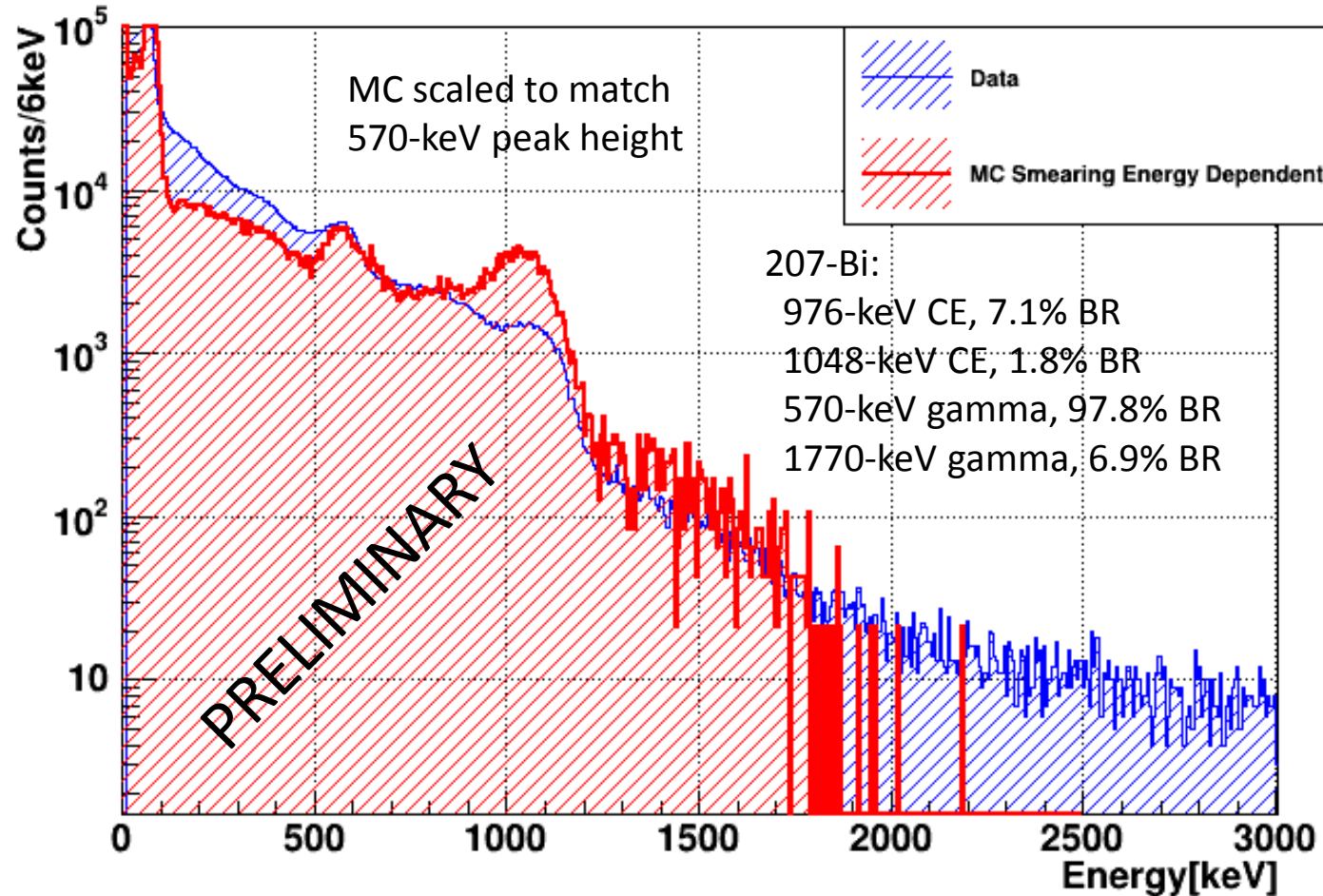

- **^{207}Bi source on cathode**
- Data collected from single strip
- Custom preamp

From EXO-200 to nEXO: higher gain photodetectors, bigger coverage

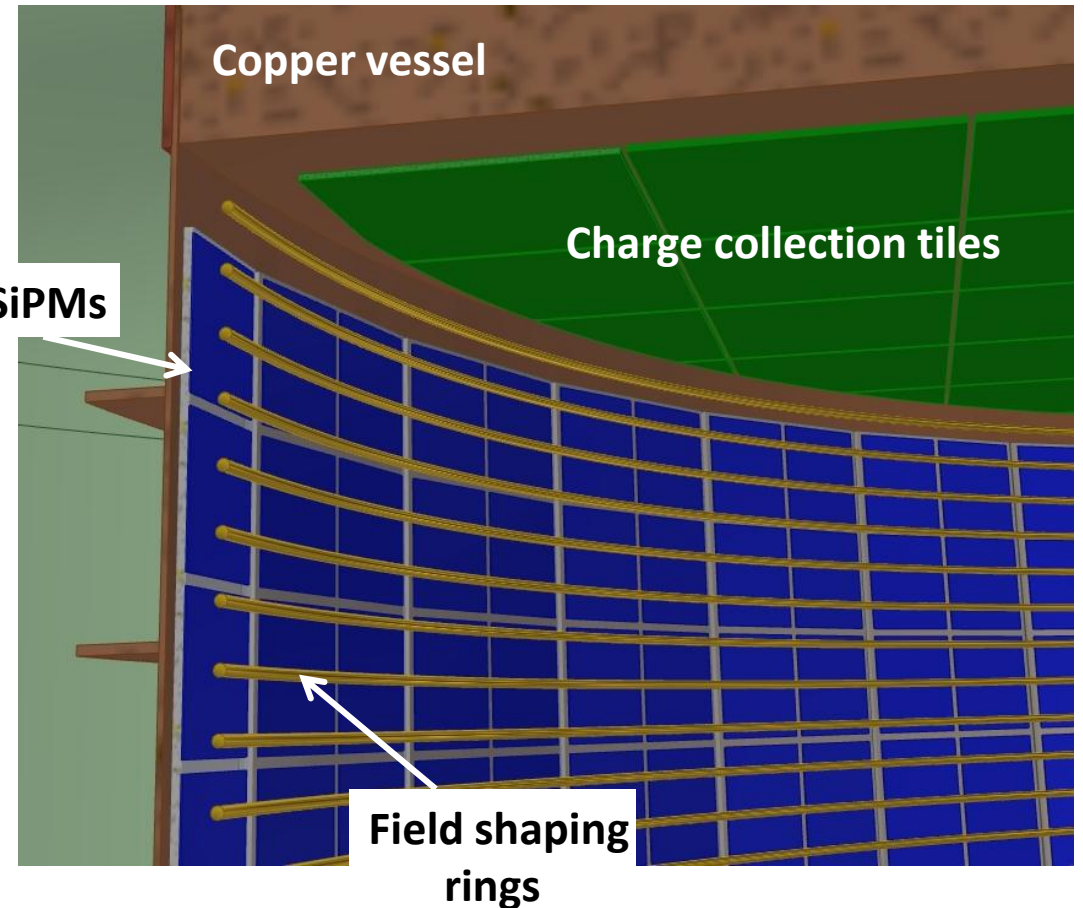
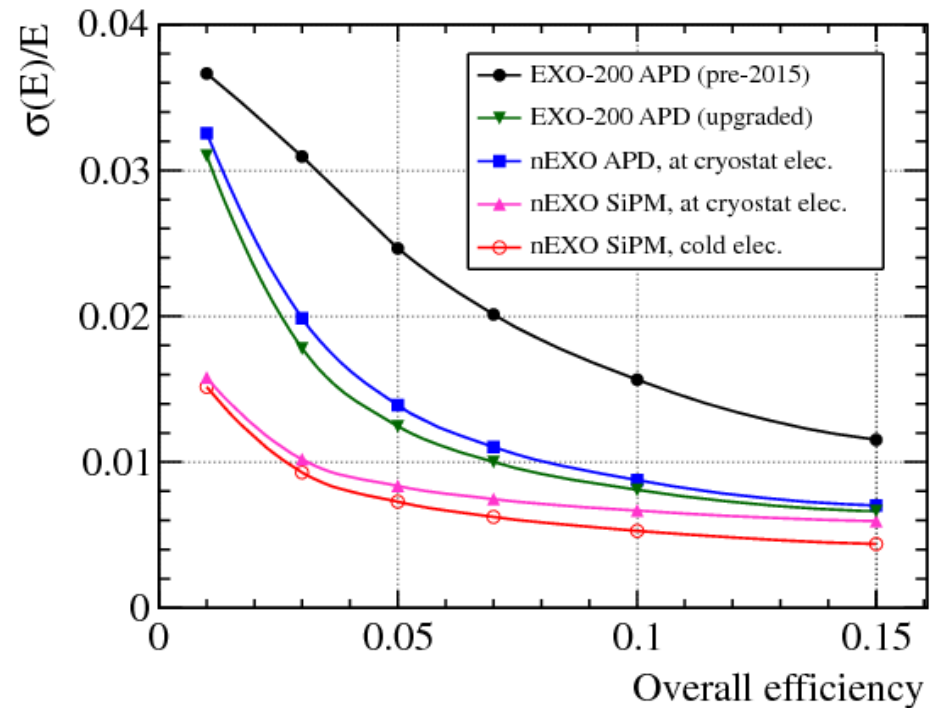

- Combine light/charge for best resolution
- APD noise limits resolution in EXO-200
- With barrel placed SiPMs, assume 1% for nEXO (but even 0.5% not impossible)

SiPM technology is almost there!

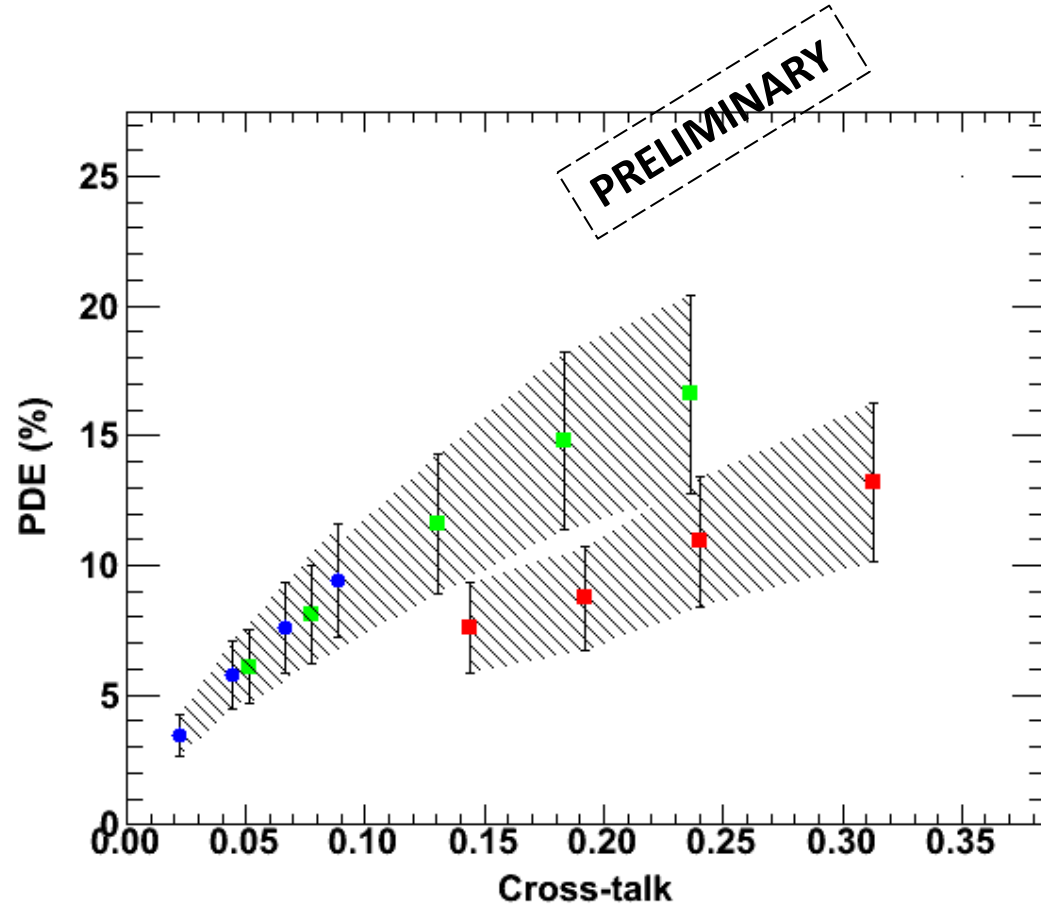

Blue – “FBK-2010”, Green – “FBK-RGBHD”, Red – “Hamamatsu-VUV2”

- Both Hamamatsu and FBK, basically, achieved min. PDE@175nm requirement (15 abs.%)
- Other parameters also improve from one production to another
- FBK readily provides bare devices for ultimate radiopurity

For recent results of nEXO R&D effort on SiPMs: *I.Ostrovskiy et al. IEEE TNS 62 (2015) 1825.*

nEXO R&D is in full swing to address remaining challenges

- High Voltage

- Need 50 kV to maintain the same field as in EXO-200
- Most LXe experiments had HV problems
- Phase 1: <3kg setup confirms breakdown from well polished surfaces at ~ 300 kV/cm
- Phase 2: 100kg “miniEXO” test setup in progress. Preliminary indication is that EXO-200 problems are specific to EXO-200
- Phase 3: Planned full scale nEXO segment with final materials. Designed in coordination with LZ

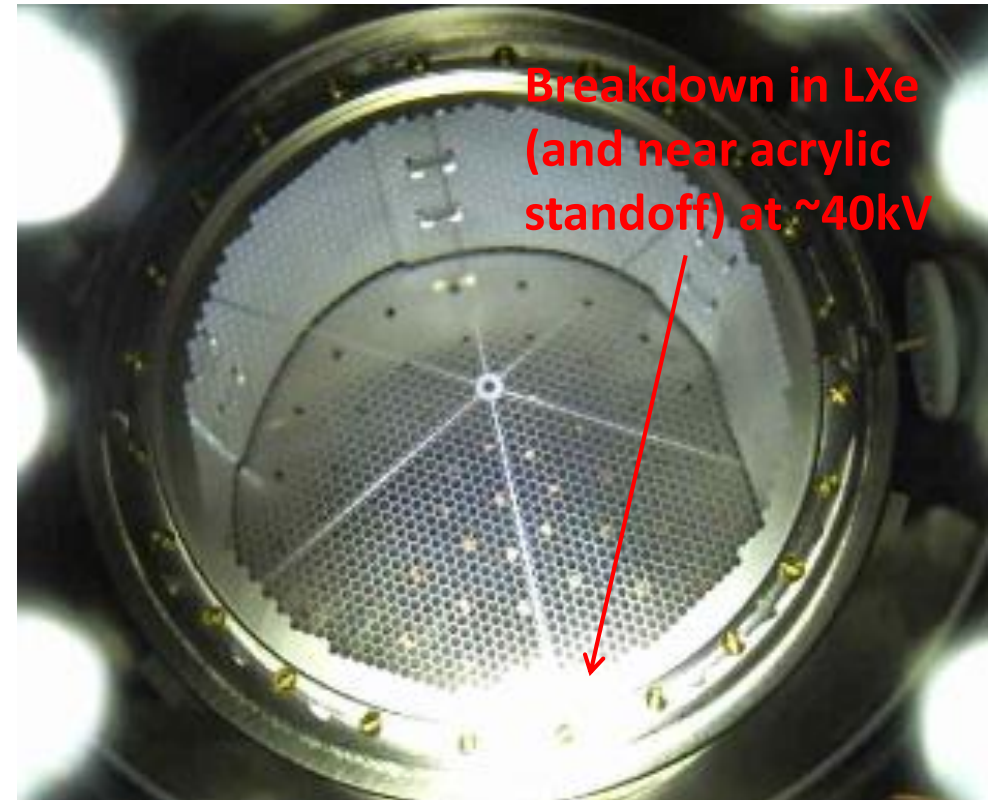

“mini-EXO” test setup

nEXO R&D is in full swing to address remaining challenges

- Cryogenic electronics
 - Cables are substantial contributor to background budget in EXO-200 and nEXO plans to further increase granularity of readout to improve topology discrimination
 - Fully integrated, ultra-low background cold electronics has not been built before
 - nEXO is working on a proof of principle chip for a $10 \times 10 \text{ cm}^2$ tile, to be tested for radiopurity and in performance in LXe



Location	Cable length (m)	Total cap (pF)	Intrinsic RMS Noise (e)	RMS contribution to charge energy resolution	Charge cluster threshold (keV)
In lab (warm)	8	800	3200	2.5%	600 keV
At cryostat (warm/cold)	2	200	800	0.6%	150 keV
Inside TPC (cold)	~0	<40	<200	0.2%	40 keV

Assumes simple tile charge collection system with interleaved strips and EXO-200 style cables for the remote location cases.

nEXO R&D is in full swing to address remaining challenges

- Also working on material radiopurity tests, simulation, calibration ideas
- Limited work on mechanical design of the vessel and cryostat
 - TPC vessel is copper, as in EXO-200
 - Considering carbon-composite cryostat (easier to construct UG, potentially cleaner, would not need as much HFE)
- Cryopit (SNO lab) as primary choice of location
 - ^{137}Xe background (~25% in EXO-200) is not an issue

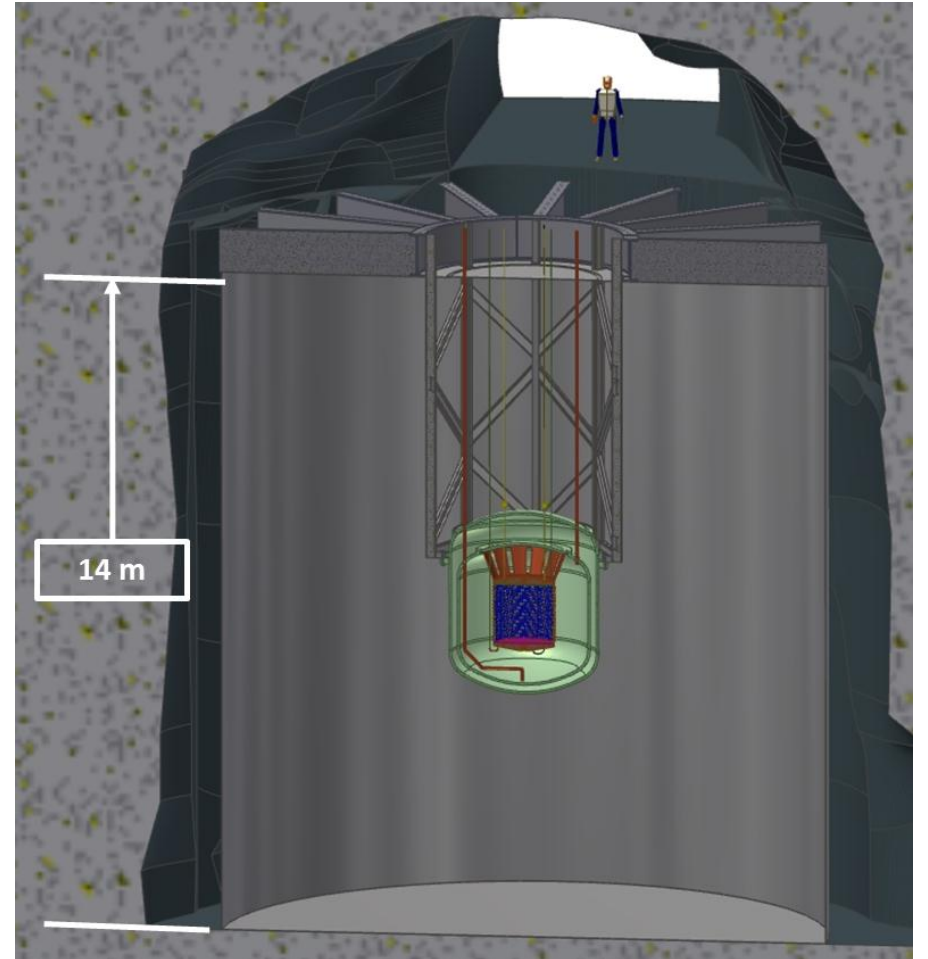

From EXO-200 to nEXO: Full list of advancements

What	Why
~30x volume/mass	To give sensitivity to the inverted hierarchy
No cathode in the middle	Larger low background volume/no ^{214}Bi in the middle
6x HV for the same field	Larger detector and one drift cell
>3x electron lifetime	Larger detector and one drift cell
Better photodetector coverage	Energy resolution
SiPM instead of APDs	Higher gain, lower bias, lighter, E resolution
In LXe electronics	Lower noise, more stable, fewer cables/feedthroughs, E resolution, lower threshold for Compton ID
Lower outgassing components	Longer electron lifetime
Different calibration methods	Very “deep” detector (by design)
Deeper site	Less cosmogenic activation
Larger vessels	5 ton detector and more shielding

Summary

- Because of its multi-parameter capabilities, nEXO has robust discovery potential
- Its general configuration was validated by successful EXO-200
- Homogeneity is a desirable feature. Required R&D is in full swing
- This is a tested collaboration that is known to be capable of successfully executing every phase of an experiment
- It is essential that this science is done in an effective and timely manner. *nEXO plans to be ready to start construction project in 2017*



University of Alabama, Tuscaloosa AL, USA — T Didberidze, M Hughes, A Piepke, R Tsang

University of Bern, Switzerland — S Delaquis, R Gornea[†], J-L Vuilleumier

[†]Now at Carleton University

Brookhaven National Laboratory, Upton NY, USA — M Chiu, G De Geronimo, S Li, V Radeka, T Rao, G Smith, T Tsang, B Yu

California Institute of Technology, Pasadena CA, USA — P Vogel

Carleton University, Ottawa ON, Canada — Y Baribeau, V Basque, M Bowcock, M Dunford, M Facina, R Gornea, K Graham, P Gravelle, R Killick, T Koffas, C Licciardi, K McFarlane, R Schnarr, D Sinclair

Colorado State University, Fort Collins CO, USA — C Chambers, A Craycraft, W Fairbank Jr., T Walton

Drexel University, Philadelphia PA, USA — MJ Dolinski, YH Lin, E Smith, T Winick, Y-R Yen

Duke University, Durham NC, USA — PS Barbeau, G Swift

University of Erlangen-Nuremberg, Erlangen, Germany — G Anton, R Bayerlein, J Hoessl, P Hufschmidt, A Jamil, T Michel, T Ziegler

IBS Center for Underground Physics, Daejeon, South Korea — DS Leonard

IHEP Beijing, People's Republic of China — G Cao, W Cen, X Jiang, H Li, Z Ning, X Sun, T Tolba, W Wei, L Wen, W Wu, J Zhao

University of Illinois, Urbana-Champaign IL, USA — D Beck, M Coon, J Walton, L Yang

Indiana University, Bloomington IN, USA — JB Albert, S Daugherty, TN Johnson, LJ Kaufman, G Visser, J Zetlemoyer

University of California, Irvine, Irvine CA, USA — M Moe

ITEP Moscow, Russia — V Belov, A Burenkov, M Danilov, A Dolgolenko, A Karelin, A Kobayakin, A Kuchenkov, V Stekhanov, O Zeldovich

Laurentian University, Sudbury ON, Canada — B Cleveland, A Der Mesrobian-Kabakian, J Farine, B Mong, U Wichoski

Lawrence Livermore National Laboratory, Livermore CA, USA — O Alford, J Brodsky, M Heffner, G Holtmeier, A House, M Johnson, S Sangiorgio

University of Massachusetts, Amherst MA, USA — J Dalmasson, S Feyzbakhsh, S Johnston, J King, A Pocar

McGill University, Montreal PQ, Canada — T Brunner

Oak Ridge National Laboratory, Oak Ridge TN, USA — L Fabris, D Hornback, RJ Newby, K Ziock

Rensselaer Polytechnic Institute, Troy NY, USA — E Brown

SLAC National Accelerator Laboratory, Menlo Park CA, USA — T Daniels, K Fouts, G Haller, R Herbst, M Kwiatkowski, K Nishimura, A Odian, M Oriunno, PC Rowson, K Skarpaas

University of South Dakota, Vermillion SD, USA — R MacLellan

Stanford University, Stanford CA, USA — R DeVoe, D Fudenberg, G Gratta, M Jewell, S Kravitz, D Moore, I Ostrovskiy, A Schubert, K Twelker, M Weber

Stony Brook University, SUNY, Stony Brook, NY, USA — K Kumar, O Njaya, M Tarka

Technical University of Munich, Garching, Germany — P Fierlinger, M Marino

TRIUMF, Vancouver BC, Canada — J Dilling, P Gumplinger, R Krücken, F Retière, V Strickland

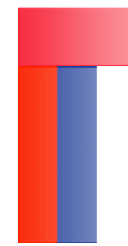

Material procurement

^{136}Xe enrichment easier and cheaper:
→ 90% enriched ^{136}Xe : ~10\$/g
90% enriched ^{76}Ge : ~90\$/g (+xtal growth)

(EXO-200 uses 80% enriched Xe. It now seems customary to do 90% and it appears that there is no major cost difference)

Exact centrifuge capacity in Russia is classified but our contacts indicate that 5000kg in 5 years is comfortable

World ^{nat}Xe production is ~40 tonnes/yr (~4000kg ^{136}Xe), however large price fluctuations are not uncommon

Almost a ton of Xe enriched in the isotope 136 has been produced in the world in the last 10 years. So this information is quite reliable.

A note on the copper that is the dominant background from the TPC vessel:

	~U, Th (ppt)
EXO-200 ICPMS measurement (Aurubis copper)	< 6, <14
EXO-200 measurement (Aurubis process)	< 4
nEXO measurement of Aurubis copper	< 1
PNNL measurement of electroformed Cu	~ 0.01

Study in progress of the Aurubis process seems to indicate that 0.1 ppt may very well be already achieved.

Background Index [in counts/(ROI·tonne·yr)] versus fiducial volume is shown for two choices of the ROI: $\pm 2\cdot\sigma$ and FWHM.

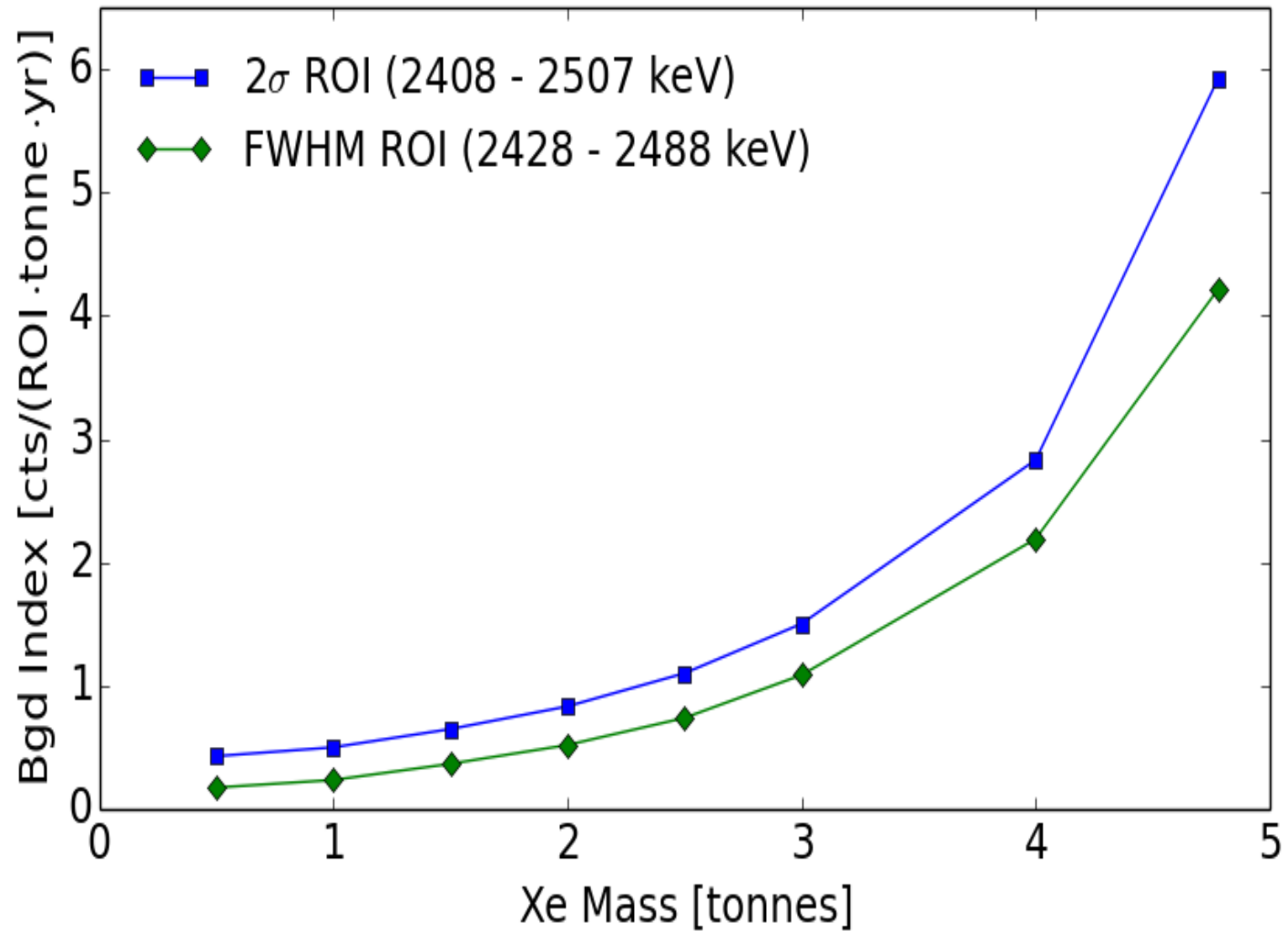

projected sensitivity 90%CL, 5 years of data (@90% live)

for the most conservative Copper background only.

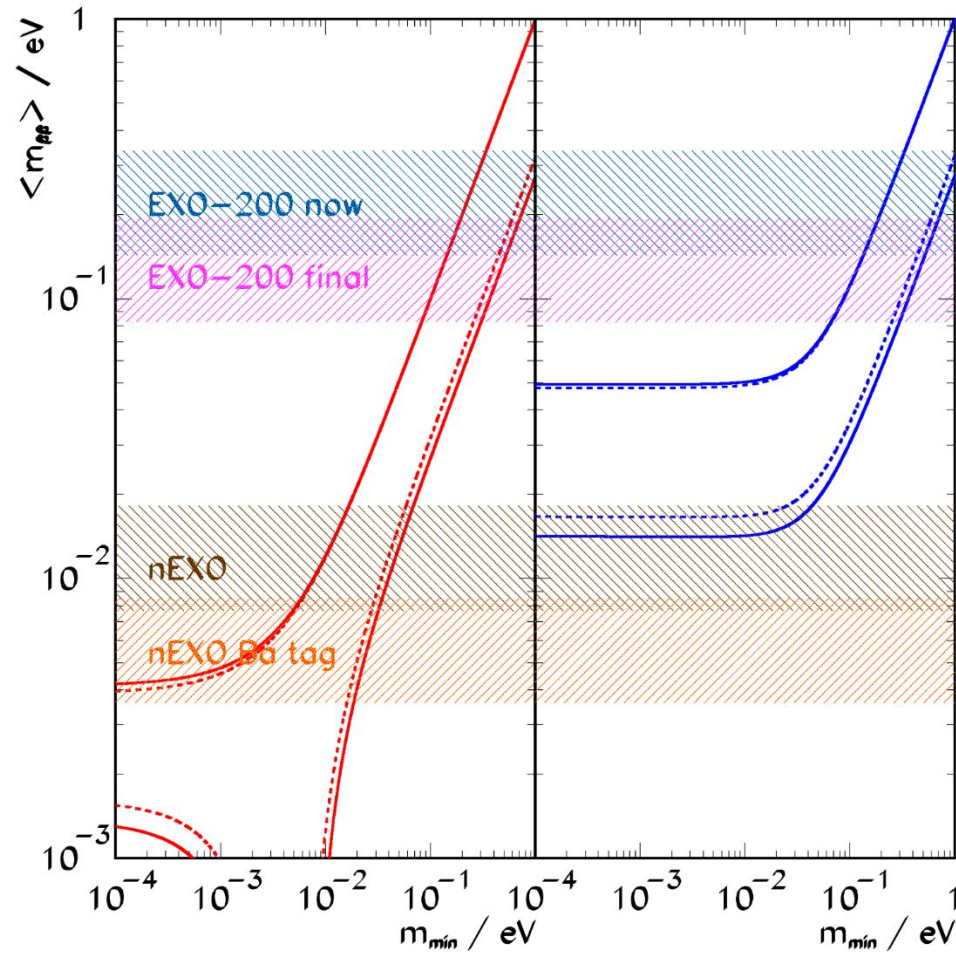

NH and IH bands are also 90%CL

Forero et al., PRD 90 (2014) 093006

Forero et al., Private Comm.

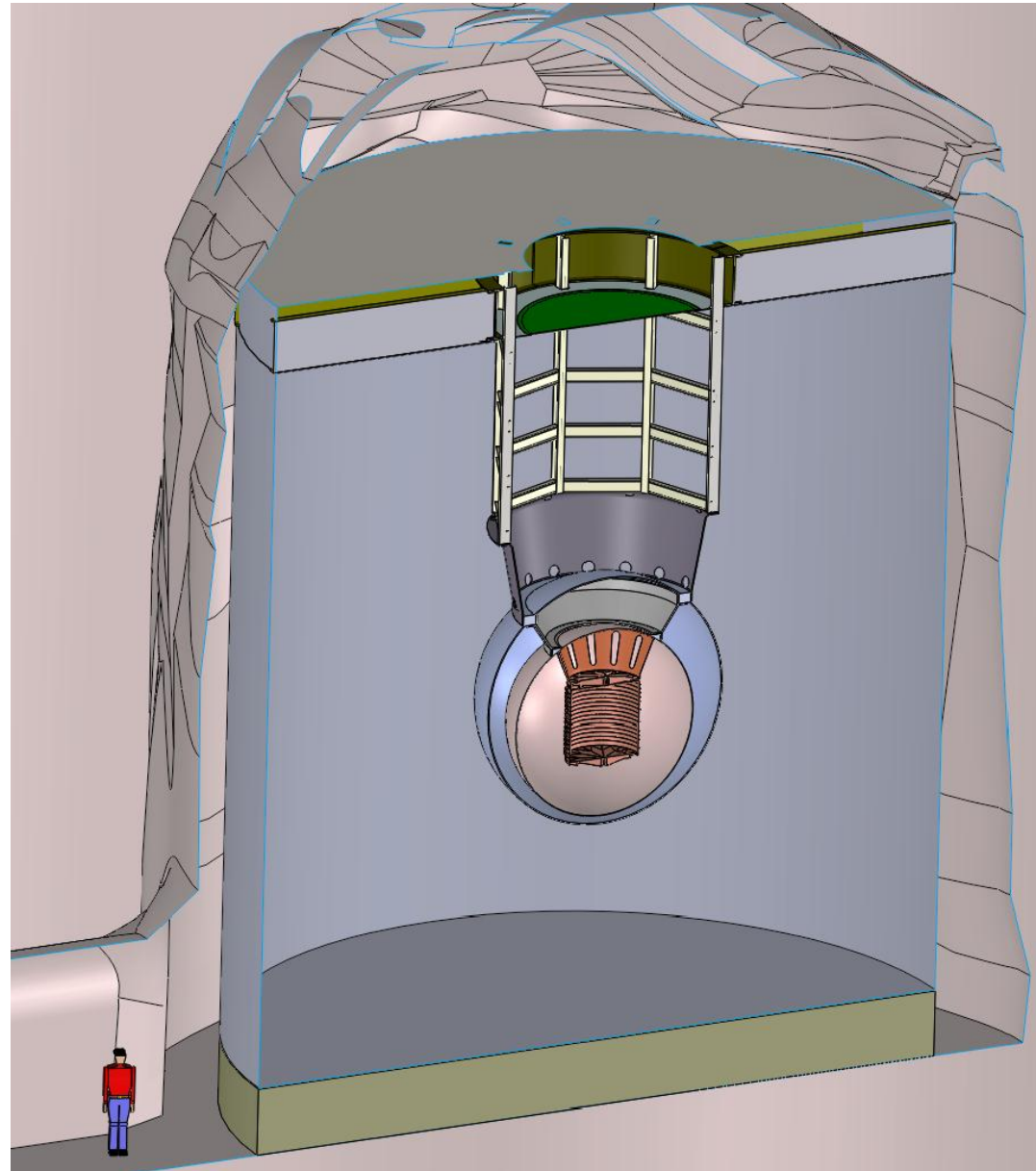

7) Radiopurity Investigations

Goal: In collaboration with all other subsystem groups, identify materials which will meet structural requirements while reducing the radioactive bkgd even further.

Risk: inadequate radioactivity qualification of detector components at this stage may result in substantial delays to identify and study materials, or even in flawed assessment of the project soundness.

The R&D: We have proactively invested in several **new facilities** and have already been successful in specific and important areas.

- Low background Ge counting: **SNOLab (underground)**, Alabama (surface), Alabama & Duke developing **new underground capability at KURF**
 - Neutron activation analysis: Alabama
 - ICPMS: **IHEP Beijing, IBS Korea**
 - GDMS: NRC Canada
 - Radon emanation: Laurentian U. Canada
- **Already improved analytical sensitivity for U and Th in Cu by 3-fold (~1ppt)**

Much work in progress to enhance capabilities and sensitivities for various specific issues/materials.

Tight coordination with the Monte Carlo effort is essential.