

R&D Towards a Next Generation Germanium Double Beta Decay Experiment

Keith Rielage



This Talk

- **R&D effort at Los Alamos National Lab funded by an internal grant (with Steve Elliott, Pinghan Chu, Ralph Massarczyk, Wenqin Xu)**
- **In cooperation with the MAJORANA Collaboration (especially Matthew Busch, Chief Engineer)**
- **Also builds on discussions between the MAJORANA and GERDA Collaborations**

$\beta\beta$ Sensitivity

(mixing parameters from arXiv:1106.6028)

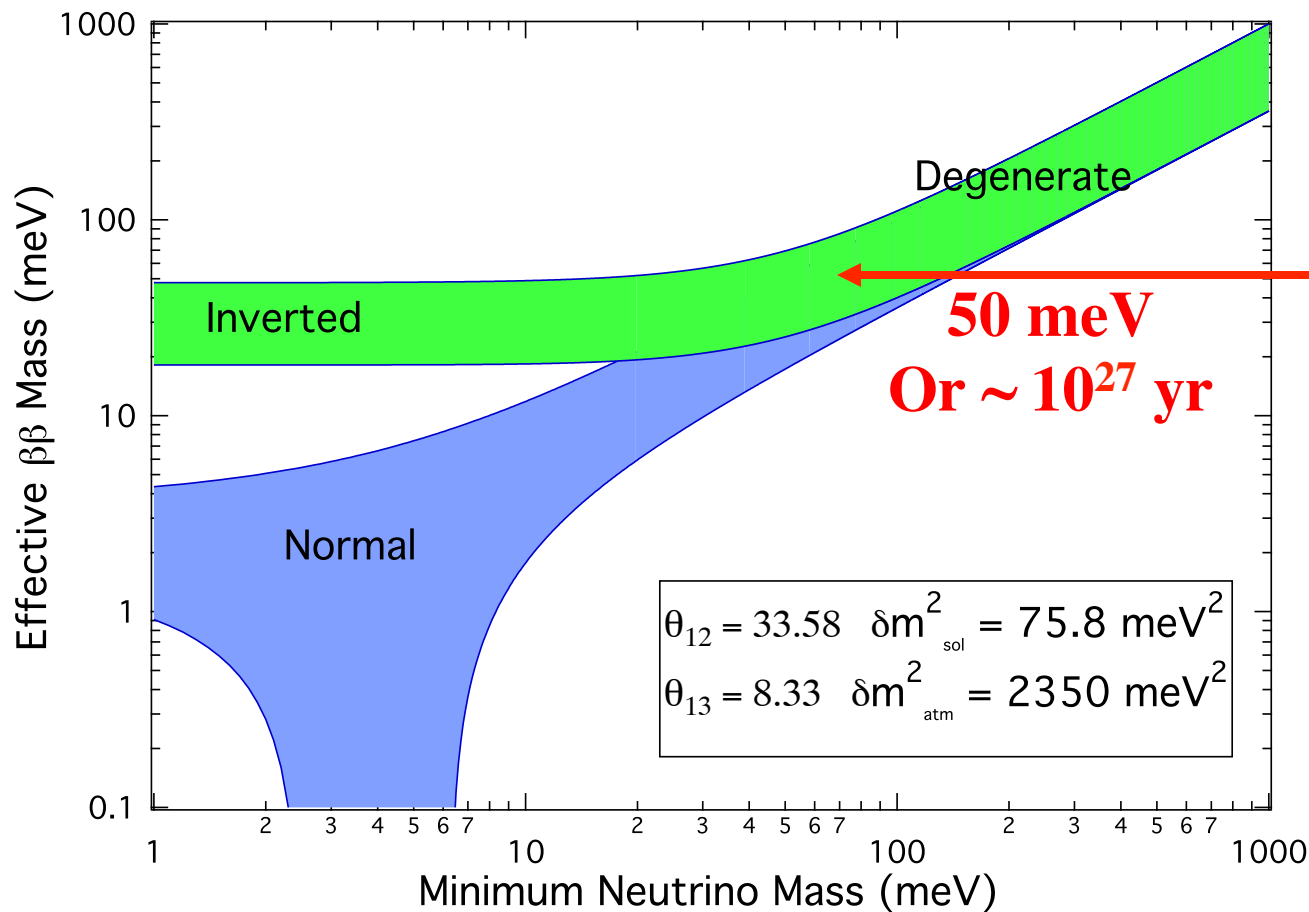

Even a null result will constrain the possible mass spectrum possibilities!

A $m_{\beta\beta}$ limit of ~ 15 meV would disfavor Majorana neutrinos in an inverted hierarchy.

Sensitivity, Background and Exposure

^{76}Ge (87% enr.)

Fig: Courtesy J. Detwiler

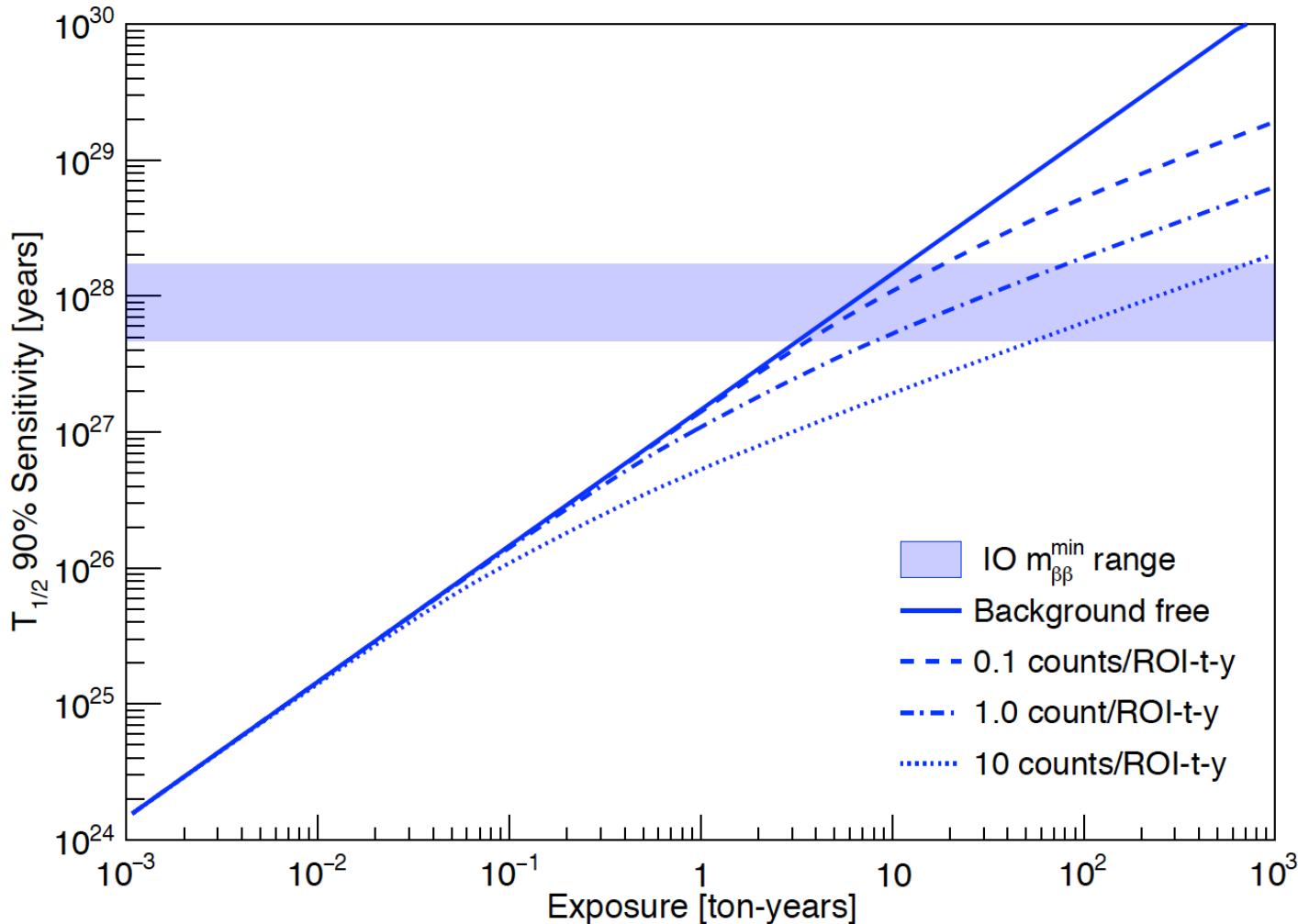

Inverted Ordering (IO)

Minimum IO $m_{\beta\beta}=18.3$ meV, taken from using the PDG2013 central values of the oscillation parameters, and the most pessimistic NME for the corresponding isotope among QRPA, SM, IBM, PHFB, and EDF

Note : Region of Interest (ROI) can be single or multidimensional (E, spatial, ...)

Discovery, Background and Exposure

^{76}Ge (87% enr.)

Fig: Courtesy J. Detwiler

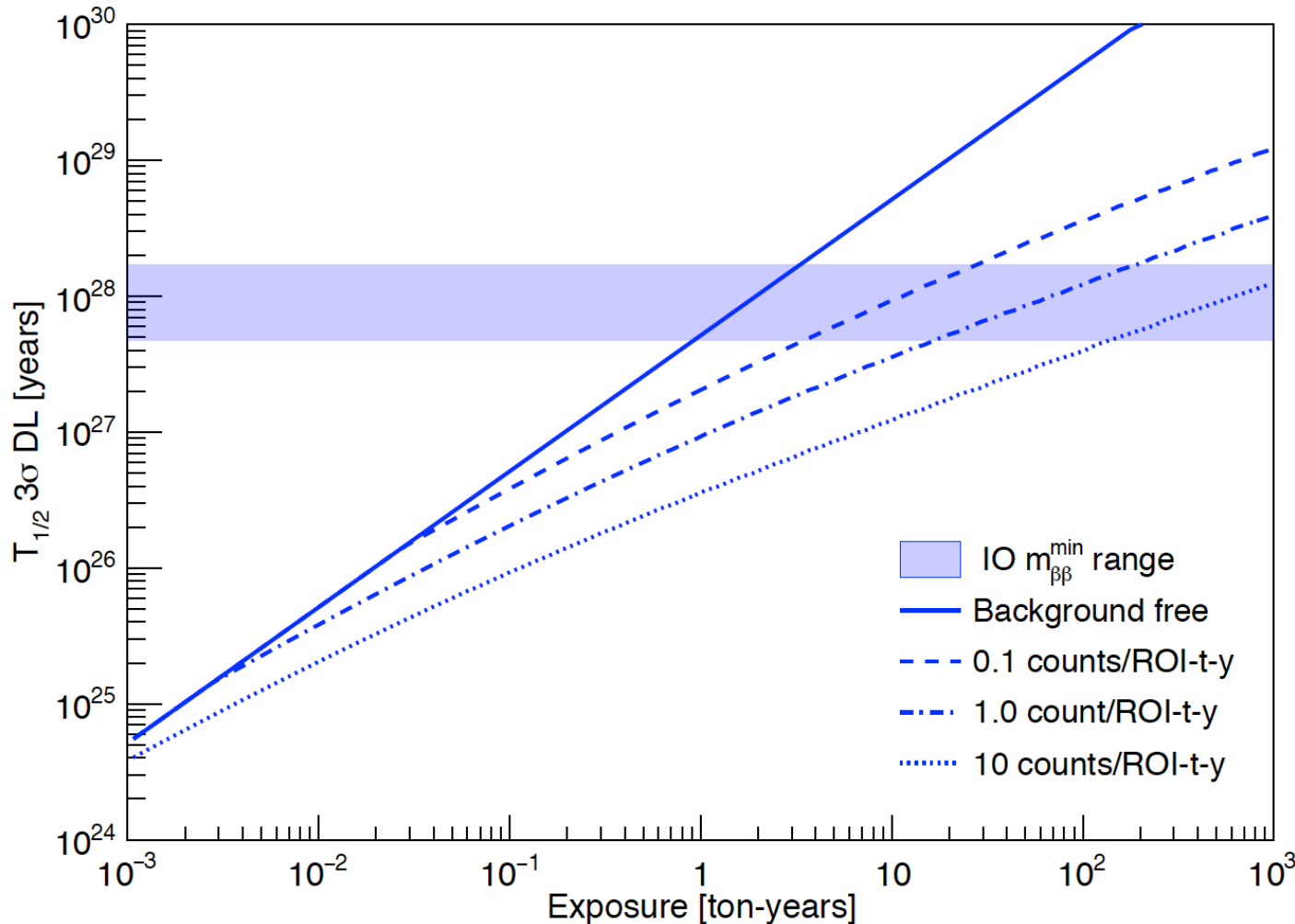

Inverted Ordering (IO)
 Minimum IO $m_{\beta\beta}=18.3$ meV, taken from using the PDG2013 central values of the oscillation parameters, and the most pessimistic NME for the corresponding isotope among QRPA, SM, IBM, PHFB, and EDF

Note : Region of Interest (ROI) can be single or multidimensional (E, spatial, ...)

U.S. NSAC Subcommittee (highlights added)

The Subcommittee recommends the following guidelines be used in the development and consideration of future proposals for the next generation experiments:

- 1.) **Discovery potential**: Favor approaches that have a credible path toward reaching 3σ sensitivity to the effective Majorana neutrino mass parameter $m_{\beta\beta}=15$ meV within 10 years of counting, assuming the lower matrix element values among viable nuclear structure model calculations.
- 2.) **Staging**: Given the risks and level of resources required, support for **one or more intermediate stages** along the maximum discovery potential path may be the optimal approach.
- 3.) **Standard of proof**: Each next-generation experiment worldwide must be capable of providing, on its own, compelling evidence of the **validity of a possible non-null signal**.
- 4.) **Continuing R&D**: The demands on background reduction are so stringent that modest scope **demonstration projects for promising new approaches to background suppression** or sensitivity enhancement should be pursued with high priority, in parallel with or in combination with ongoing NLDBD searches.
- 5.) **International Collaboration**: Given the desirability of establishing a signal in multiple isotopes and the likely cost of these experiments, it is important to coordinate with other countries and funding agencies to develop an **international approach**.
- 6.) **Timeliness**: It is desirable to push for results from at least the first stage of a next-generation effort on **time scales competitive** with other international double beta decay efforts and with independent experiments aiming to pin down the neutrino mass hierarchy.

The MAJORANA DEMONSTRATOR (MJD)



Funded by DOE Office of Nuclear Physics and NSF Particle Astrophysics, with additional contributions from international collaborators.

- Goals:**
- Demonstrate backgrounds low enough to justify building a tonne scale experiment.
 - Establish feasibility to construct & field modular arrays of Ge detectors.
 - Searches for additional physics beyond the standard model.

- Located underground at 4850' Sanford Underground Research Facility
- Background Goal in the $0\nu\beta\beta$ peak region of interest (4 keV at 2039 keV) **3 counts/ROI/t/y (after analysis cuts) Assay U.L. currently ≤ 3.5 scales to 1 count/ROI/t/y for a tonne experiment**
- 44-kg of Ge detectors
 - 29.65 kg of 87% enriched ^{76}Ge crystals
 - 15 kg of $^{\text{nat}}\text{Ge}$
 - Detector Technology: P-type, point-contact.
- 2 independent cryostats
 - ultra-clean, electroformed Cu
 - 20 kg of detectors per cryostat
 - naturally scalable
- Compact Shield
 - low-background passive Cu and Pb shield with active muon veto

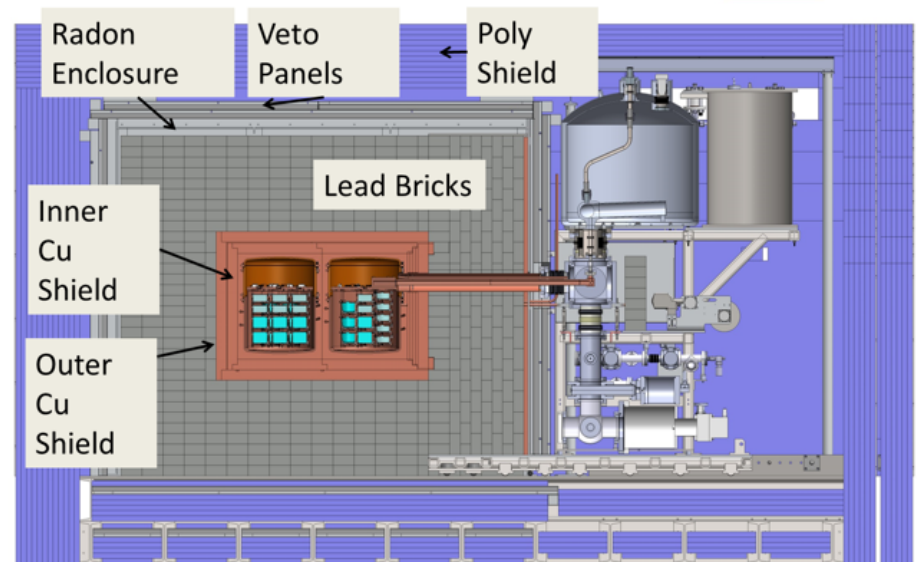
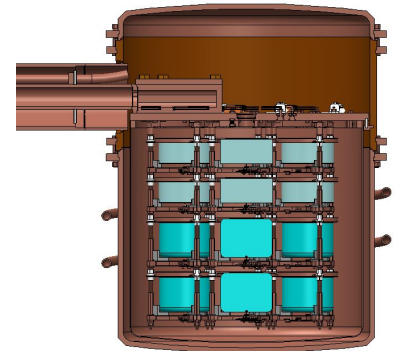

GERDA – Phase I & II



clean room
with lock

590m³ pure water
muon veto &
neutron absorber

64m³ liquid argon (LAr)
coolant & shielding

GERDA Phase I (Nov 2011- May 2013)

- 4 strings with HPGe detectors:
 - 5 HDM experiment
 - 3 IGEX experiment
 - 5 new BEGe detectors
- Total exposure 21.6 kg yr

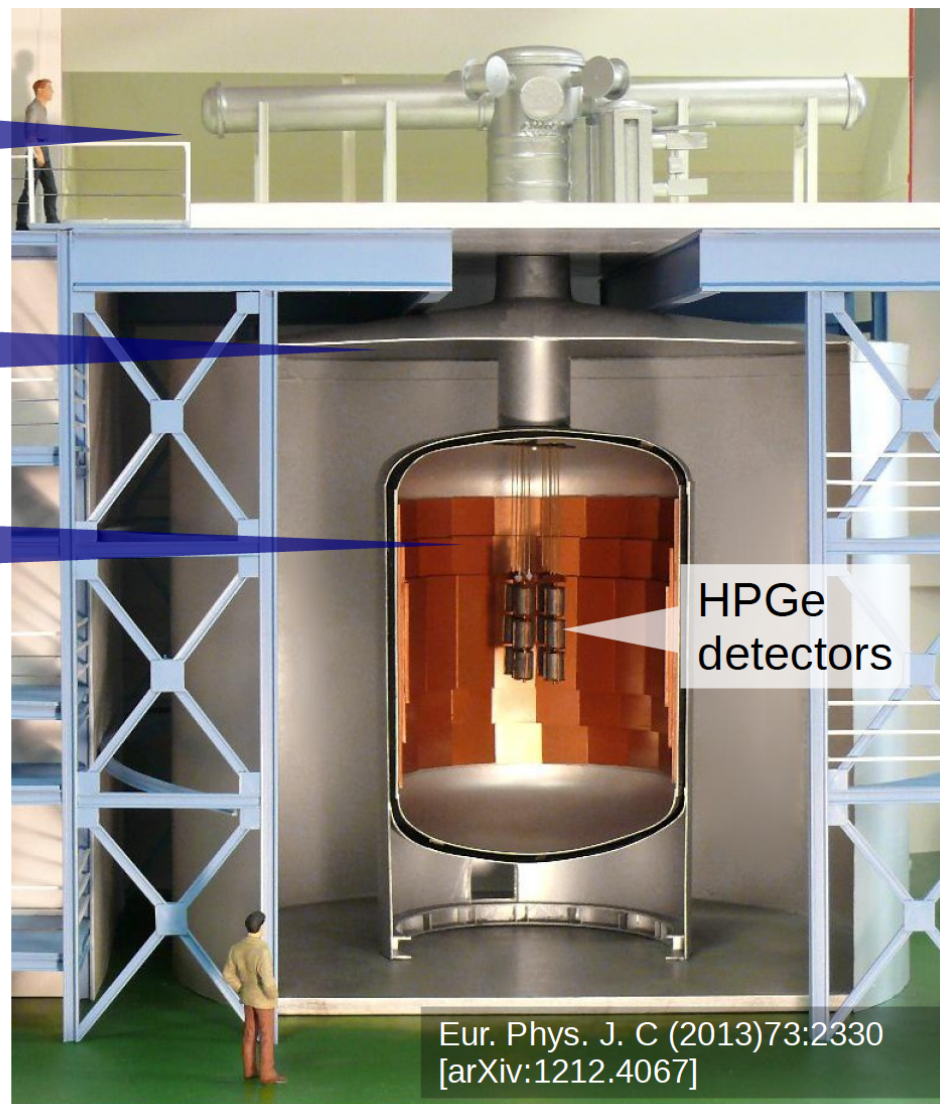

GERDA – Phase I & II



clean room
with lock

590m³ pure water
muon veto &
neutron absorber

64m³ liquid argon (LAr)
coolant & shielding

GERDA Phase II (Commissioning started April 2015)

- Additional 25 new BEGe detectors
 - ~35 kg total mass
- Goal: $T_{1/2}^{0\nu}$ in range of 10^{26} years
- Integration of LAr light detection for background rejection

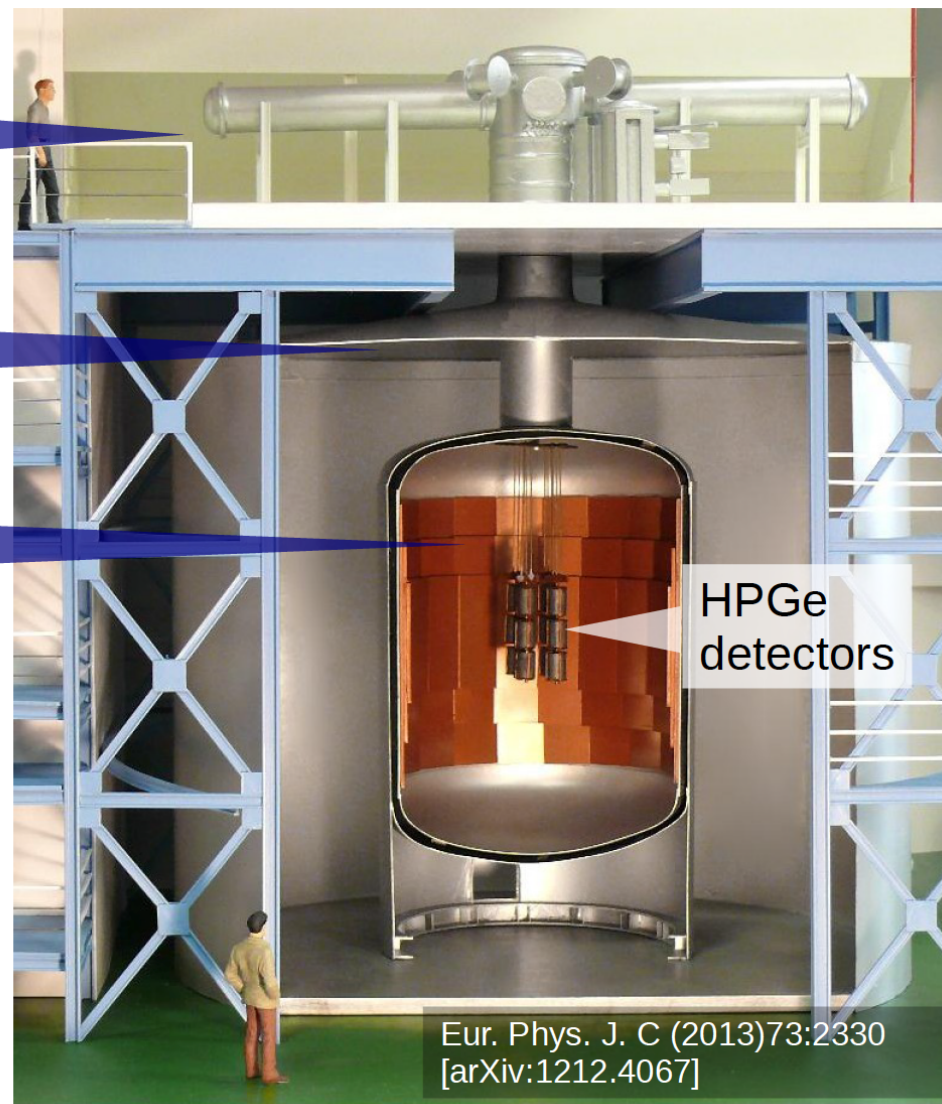

Eur. Phys. J. C (2013)73:2330
[arXiv:1212.4067]

Program Designed Around Experimental Sensitivity

$$MT = (2.50 \times 10^{-5} \text{meV})^2 \frac{NW}{fx \in G_{0\nu}} \left(\frac{1}{\langle m_{\beta\beta} \rangle M_{0\nu} g_A^2} \right)^2$$

$$N = \sqrt{B} = \sqrt{b \Delta E MT} \text{ background limited}$$

- **Need Background Low**
 - Searching for a very small peak on a continuum
- **Need to understand matrix element and g_A**
 - Will determine ultimate size of experiment
 - Effort ongoing by theorists
- **Need a large exposure (MT=10 ton-yr)**
 - A lot of detectors, which implies automation

Learn From DEMONSTRATOR Background

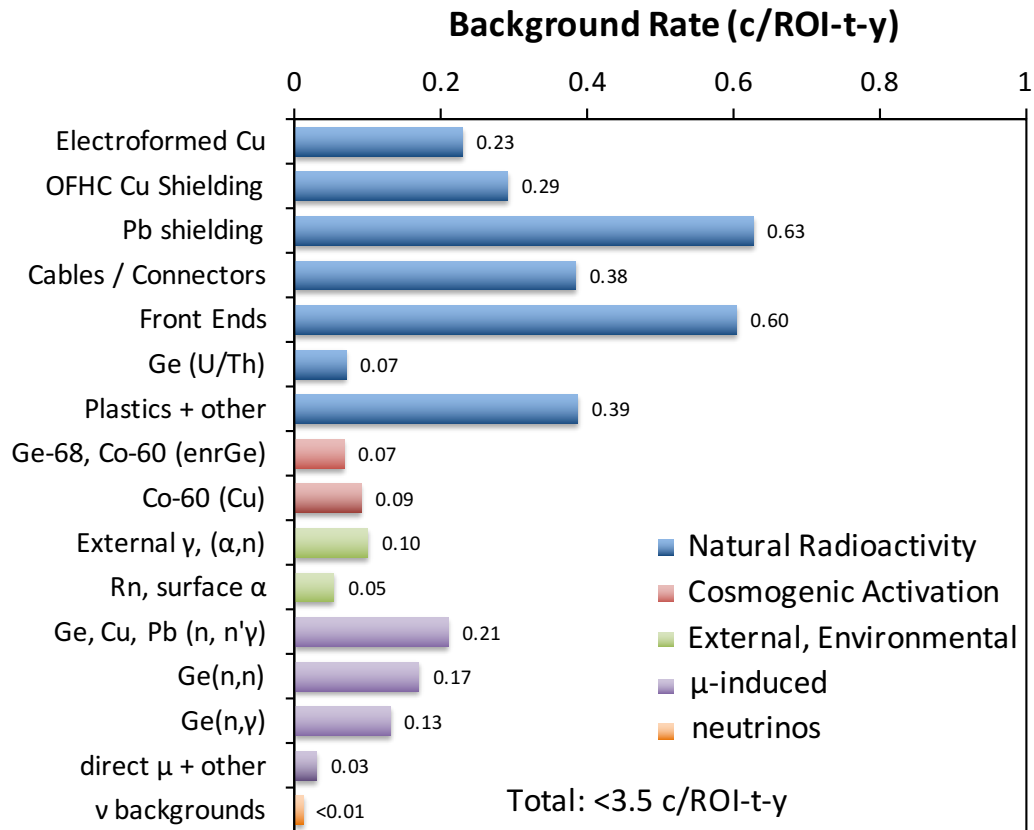

How to reach $\ll 1$ ct/t/yr:

Learn From DEMONSTRATOR Background

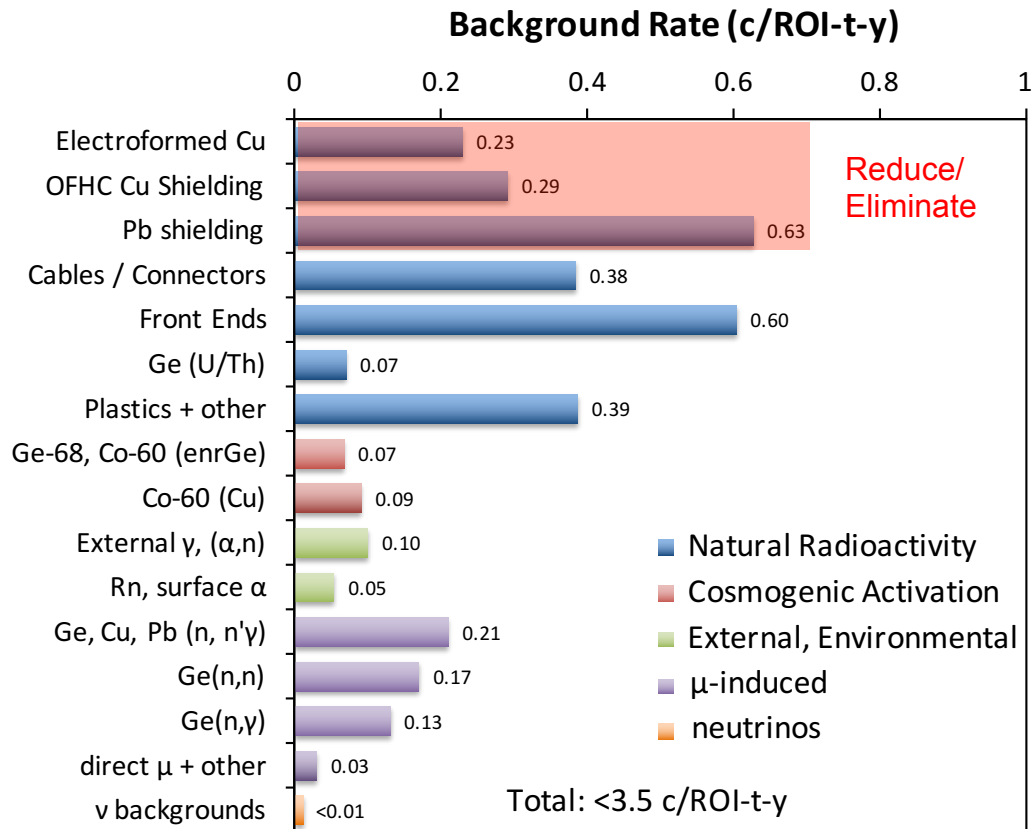

How to reach $\ll 1$ ct/t/yr:

- Active shield/hybrid

Learn From DEMONSTRATOR Background

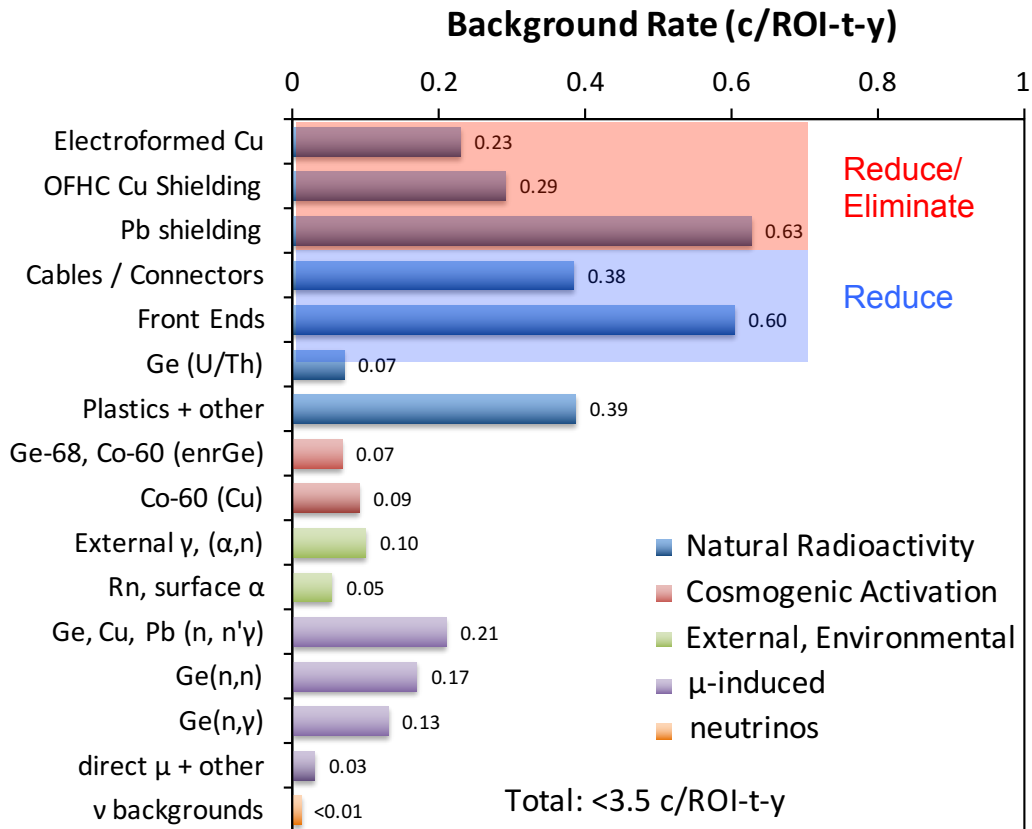

How to reach $\ll 1$ ct/t/yr:

- Active shield/hybrid
- Improve electronics purity, multiplexing, ASIC

Learn From DEMONSTRATOR Background

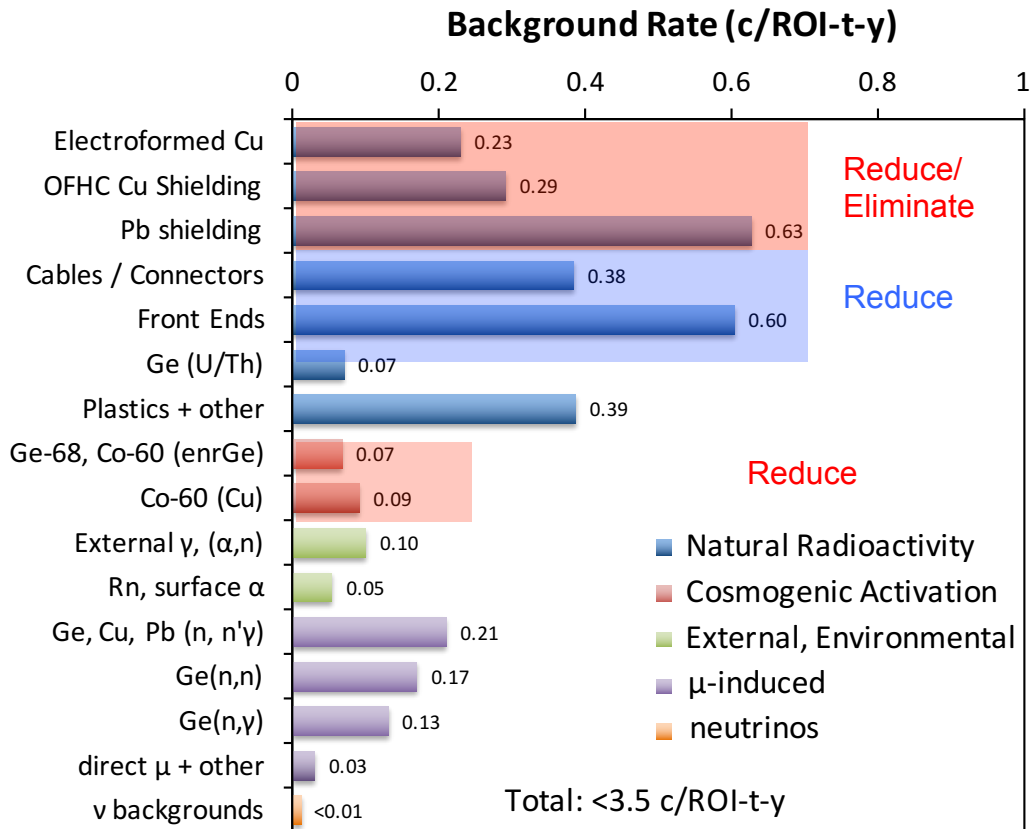

How to reach $\ll 1$ ct/t/yr:

- Active shield/hybrid
- Improve electronics purity, multiplexing, ASIC
- Understand surface exposure of detectors

Learn From DEMONSTRATOR Background

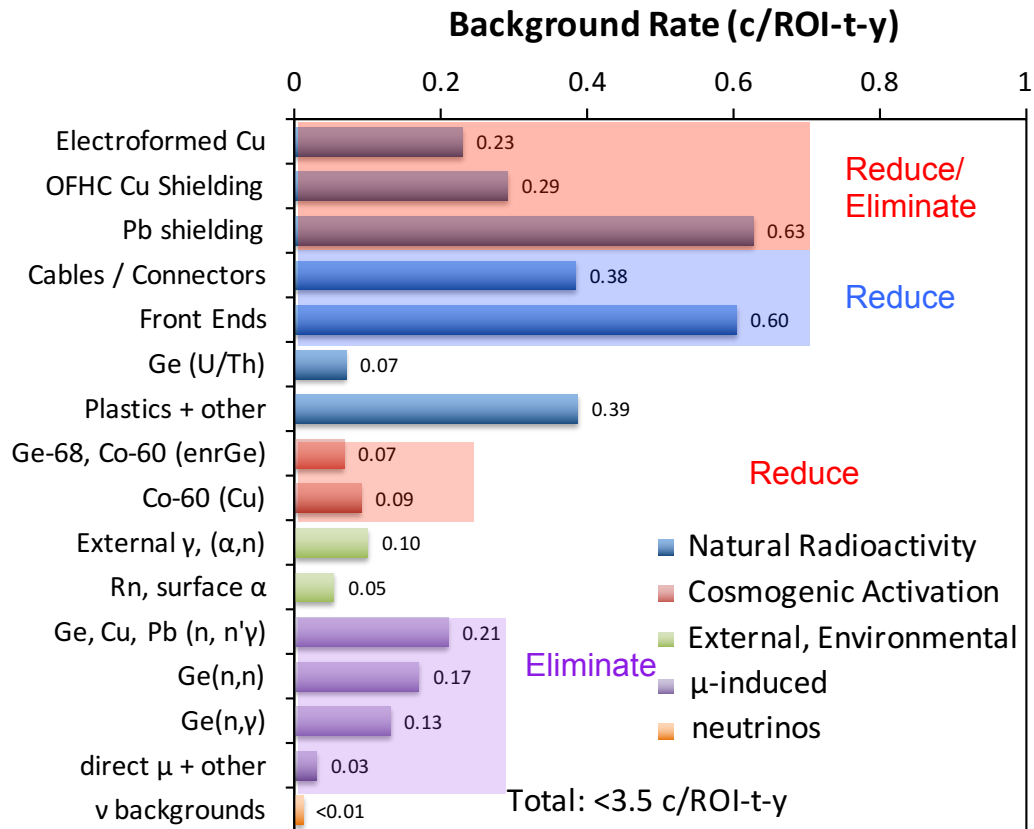

How to reach $\ll 1$ ct/t/yr:

- Active shield/hybrid
- Improve electronics purity, multiplexing, ASIC
- Understand surface exposure of detectors
- Determine necessary depth for experiment

Hybrid Cryostat/Shielding

- Passive shielding comes with increased backgrounds that are hard to further reduce (Pb, copper, etc.)
- Active shielding (LAr) comes with ^{42}K but simplicity in cooling detectors
- Exploring hybrid approach
 - Strings of Ge detectors are cooled by pure N_2 gas inside a sealed electroformed copper cryostat sitting in a LAr active shield
 - Only connections will be electrical once cryostat is sealed

Hybrid Cryostat/Shielding

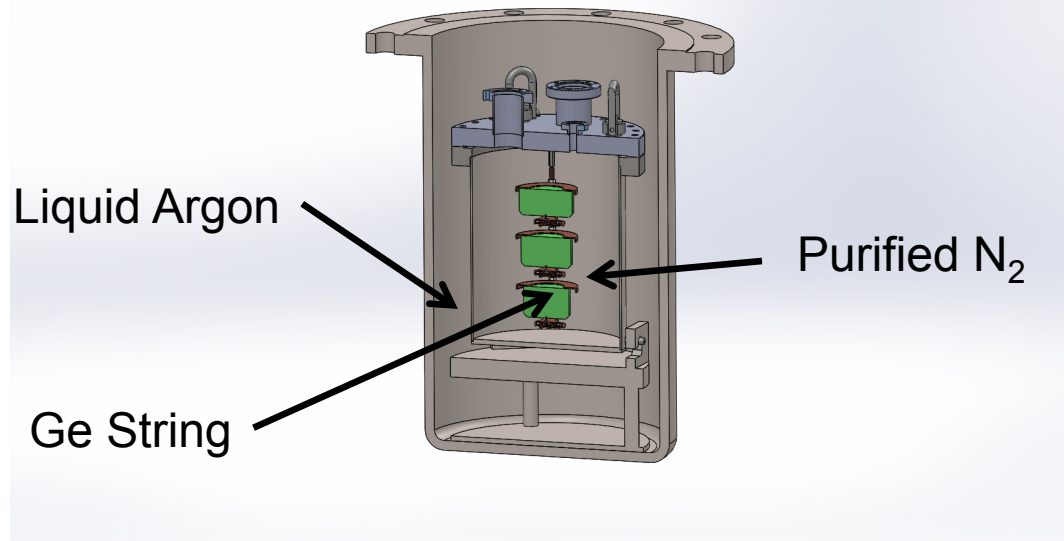

- Three phases of R&D:
 - Built a stainless steel version to test Ge operation in N₂ gas
 - Currently checking the high voltage Paschen curve for cold N₂ gas
 - Develop necessary cryogenic feedthroughs and seals for copper cryostat submerged in LAr
 - Build and test full copper cryostat version

Automation/Robotics

- Over 1000 Ge detectors for a tonne-scale experiment
- Use of automation for detector acceptance and characterization
- Possibly for assembly if detector/string unit are simple enough



- Using a robot from ST Robotics to position sources for:
 - Dead layer measurements
 - Acceptance (energy resolution, etc.)

Cables/Connectors

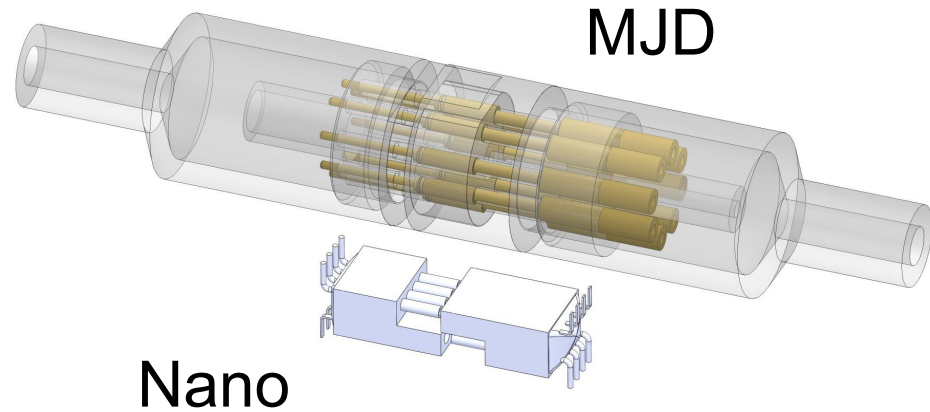
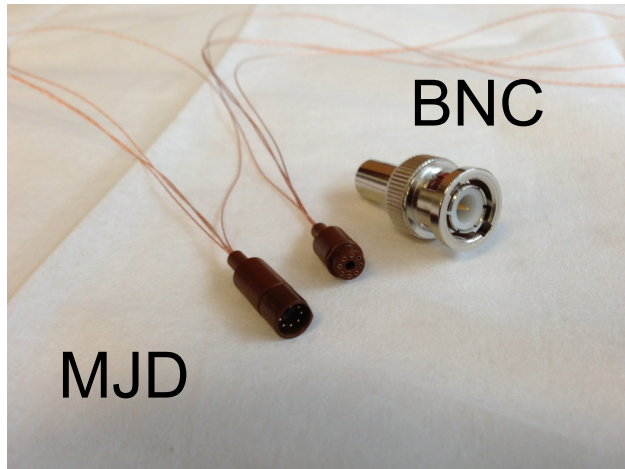

- Reduce signal connector size – pursuing commercial nanoconnectors
 - Need to work with manufacturers on using new alloys instead of BeCu
- Reduce cable number (by multiplexing) and improve purity
 - continue to work with manufacturers on cleanliness procedures

Multiplexing

- **Length and number of cables could be reduced by multiplexing the signals from a string of detectors**
- **Examining time domain and frequency domain methods of multiplexing signal**
- **LANL has expertise in multiplexing signals for ~100 channels for diagnostic experiments**
- **Could then develop an ASIC to do amplification and multiplexing near the string to reduce number of long cables needed from cryostat/string through active shield**

Depth/Cosmogenic Studies

- **Using MJD data to learn how neutrons and muon interactions produce background as a function of depth**
 - **Largest impact on where to site a tonne-scale experiment**
- **Also evaluate effects of cosmogenic background to understand surface exposure during detector production (Ge-68, Co-60)**

Summary

- **Next generation experiment needs to reduce backgrounds while scaling up in size**
- **Exploring hybrid cryostat approach**
- **Development of smaller, radiopure connectors, and multiplexing electronics, and reduced cable number**
- **Utilizing data to set necessary depth for experiment and determine detector production mitigation strategy**